

# ESQUIRE MECHANICAL CORP.

718-625-4006 • Fax 718-625-0155 • [sales@dunhill-esquire.net](mailto:sales@dunhill-esquire.net)

## INSTRUCTIONS FOR TIGHTENING SPIT MOTOR BROACH ON CM-4 MACHINES

WHEN WORKING ON THIS MACHINE, DISCONNECT ALL ELECTRICAL POWER TO MACHINE

1. Remove two (2) PHILLIPS head screws holding down end panel at spit motor compartment on CM-4 machines.
2. Lift up end panel and remove on CM-4 machine.
3. Using a 1/8" ALLEN wrench tighten ALLEN screw on broach at spit motor. Make sure spit fits properly into slot at spit handle as shown. Allow some play at spit handle slot and resting point (illustration "A")
4. Replace end panel and plug unit in.

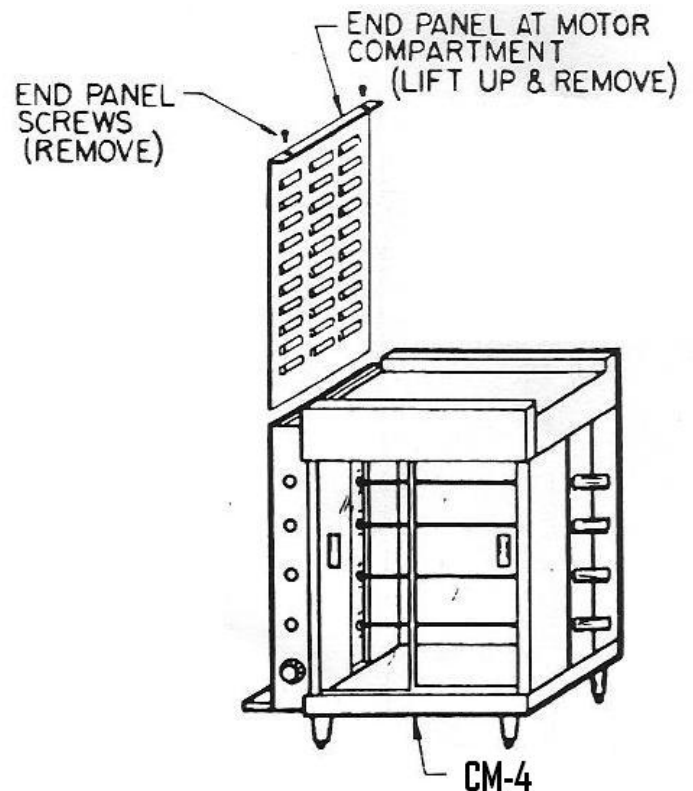
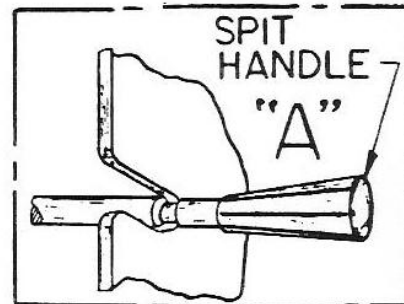
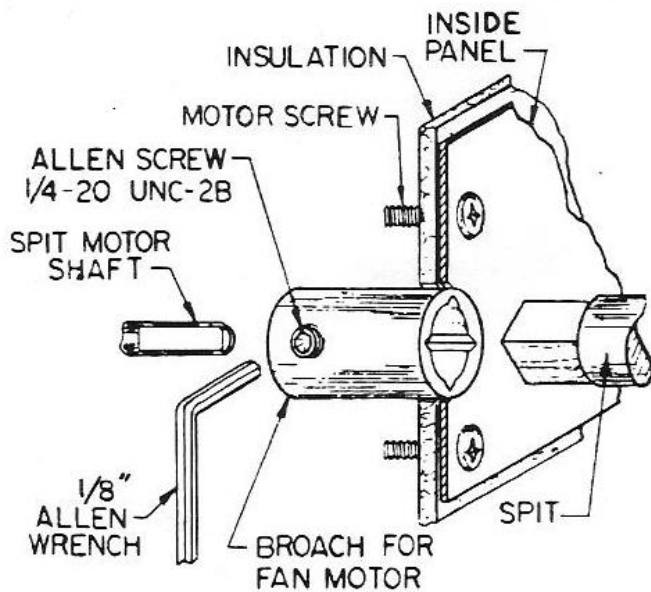

## TIGHTENING SPIT MOTOR BROACH